

embit

# EMB-LR1280S Datasheet



Embit s.r.l.

**Revision 0.5 (Preliminary)**

18/02/2021

**Document information**

**Versions & Revisions**

Revision	Date	Author	Comments
0.1	2021-02-09	Embit	Initial release
0.5	2021-02-18	Embit	Preliminary version

PRELIMINARY

## Index

1	Introduction.....	4
1.1	Specifications .....	4
1.2	Applications.....	5
2	Description .....	5
2.1	Block Diagram .....	5
2.2	STM32L073 .....	5
2.3	Transceiver.....	6
2.4	Antenna.....	6
2.5	Security Element.....	6
2.6	Crystals .....	7
2.7	Firmware .....	7
2.8	Development tools .....	7
3	Size and footprint .....	8
3.1	Size .....	8
3.2	Suggested footprint.....	9
3.3	Notes.....	10
4	Connections.....	11
4.1	Module pinout.....	11
4.2	Typical application circuit.....	12
5	Electrical characteristic .....	13
6.1	Absolute Maximum Ratings.....	13
6.2	Operating Conditions .....	13
6.3	Power Consumption.....	13
6.4	RF Characteristics .....	14
6	References .....	15
7	Disclaimer of liability .....	16
7.1	Handling Precautions .....	16
7.2	Limitations .....	16
7.3	Disclaimer of Liability.....	16
7.4	Trademarks .....	16

# 1 Introduction



**EMB-LR1280S** is the new ultra-low power 2.4 GHz band based OEM EMBit module. It exploits Semtech® proprietary spread spectrum modulation technique to provide long range connectivity and high-interference immunity, outperforming any other 2.4 GHz technology in terms of communication range. The radio is fully compliant with the worldwide 2.4 GHz frequency band regulation and can operate anywhere in the world. Also, the use of

the 2.4 GHz ISM radio band, being not subject to duty cycle, allows to enhance the overall transmission rate with respect to others sub 1-GHz solutions.

**EMB-LR1280S** is based on Semtech®'s SX1280 long range 2.4 GHz transceiver coupled with STM32L073 MCU. The MCU is equipped with up to 192 KB Flash memory and up to 20 KB of RAM memory. The module integrates two crystals, one at 52 MHz and one at 32 KHz and a Crypto Unit to protect the communication between the module and external interfaces, enhancing data security.

**EMB-LR1280S** can communicate with other devices through a wide range of serial interfaces: UART, I2C, USB, SPI, several digital and analog I/O ports useful for the management of external devices and interfaces. Moreover, the extremely reduced low power consumption provided by the STM32L073 MCU, makes the **EMB-LR1280S** particularly suitable to implement long life battery powered devices.

## 1.1 Specifications

- Operating Voltage: 1.8 - 3.6 V
- MCU: Arm Cortex-M0+ 32-bit STM32L073
- 20 KB RAM, 192KB Flash
- Transceiver Semtech® SX1280
- RF output power up to 12 dBm
- RF sensitivity down to -132 dBm at 595 bps
- Modulation: LoRa® Spread Spectrum, FLRC, (G)FSK
- Operating Frequency: 2.4 Ghz
- Frequency Range: 2400 MHz to 2485 MHz
- Interfaces: UART/LPUART/I2C/SPI/ADC/USB/GPIOs
- Dimensions: 15.5 x 20 x 2.3 mm
- Temperature Range: -40°C to +85°C
- U.FL connector or ceramic antenna
- Crypto Unit to protect communication

## 1.2 Applications

The device can be used in several applications where LoRa® gateway is needed, such as:

- Internet of Things (IoT)
- Automated Meter reading
- Smart cities
- Home Building Automation
- Wireless Alarm and Security System
- Machine to Machine (M2M)
- Industrial Monitoring and Control
- Smart lighting
- Long Range Irrigation System

## 2 Description

### 2.1 Block Diagram

The **EMB-LR1280S** block diagram:

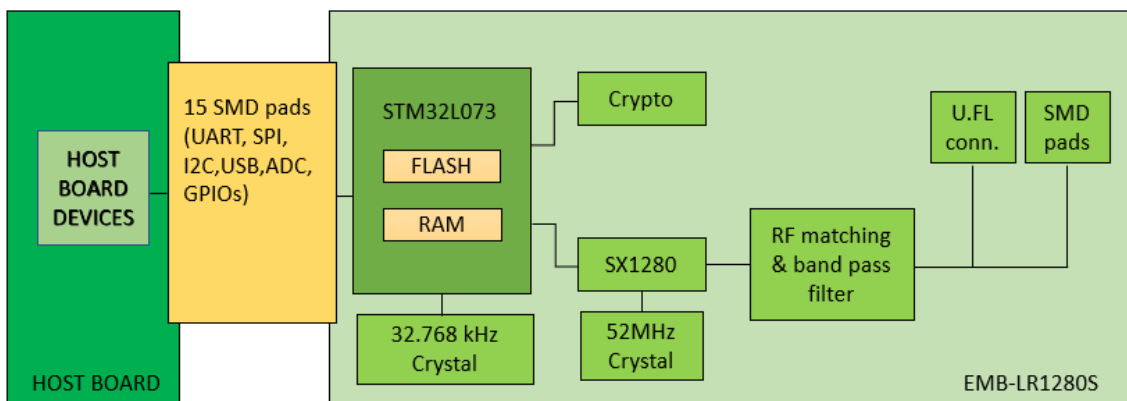

Figure 1: EMB-LR1280S block diagram.

### 2.2 STM32L073

The **EMB-LR1280S** embeds an STM32L073[1] MCU. It's an ultra-low-power, high-performance microcontroller based on an ARM Cortex M0+ 32 bit core operating at 32MHz. It is characterized by high speed embedded memories (192KBytes of data EEPROM, 20KBytes of RAM) and a Memory Protection Unit (MPU). The power management is highly effective and flexible thanks to the

availability of 8 power modes, internal voltage adaptation and multiple internal/external clock sources. The MCU offers a wide range of standard and advanced interfaces such as I2C, SPI, USART, LPUART and a crystal-less USB. Moreover it embeds multiple analog and digital resources: 12-bit ADC with hardware oversampling, one RTC unit, multiple timers (with one low power timer), SysTick, programmable watchdog timer and multiple GPIOs. The MCU is programmed and debugged via SWD (ARM Serial Wire Debug) that represents a fast 2-pin standard interface.

## 2.3 Transceiver

The Semtech® **SX1280**[2] is an half-duplex transceiver that provides ultra-long range communication, high interference immunity with minimized current consumption in the 2.4 GHz band. Other than LoRa®, the **SX1280** supports FLRC and (G)FSK radio modulations and it is compatible with the BLE physical layer. The maximum transmit power is 12.5 dBm with a receiver sensitivity of -132 dBm @595 bps with LoRa® modulation @SF12 and 203KHz Bandwidth. The transceiver also offers a ranging engine with time of flight functionalities.



## 2.4 Antenna

The **EMB-LR1280S** comes with two antenna options:

- Ceramic antenna: 2.4 GHz integrated antenna
- External antenna connector: 50  $\Omega$  single-ended U.FL connector

## 2.5 Security Element

The **EMB-LR1280S** features a crypto unit for protection, encryption and data security. This Security element is a high-security cryptographic device which combines world-class hardware-based key storage with hardware cryptographic accelerators to implement various authentication and encryption protocols.

The includes an EEPROM array which can be used for storage of up to 16 keys, certificates, miscellaneous read/write, secret data, and security configurations. Access to the various sections of memory can be restricted in a variety of ways and then the configuration can be locked to prevent changes.

It can be used as an Ecosystem control and Anti-Counterfeiting and validates if a system or component is authentic and came from the OEM shown on the name plate. Access to the device is made through a standard I2C Interface at speeds of up to 1 Mb/s.

## 2.6 Crystals

The **EMB-LR1280S** embeds two crystals:

- One 52MHz crystal required by the digital PLL of the transceiver to perform RF and baseband frequency conversion.
- One 32KHz crystal to be used as external clock source.

## 2.7 Firmware

The **EMB-LR1280S** comes with Semtech® LoRa® 2.4 GHz stack, extended with Embit additional features and with proprietary **LoRaEMB** stack.

## 2.8 Development tools

To work with **EMB-LR1280S** the following tools are suggested:

- **STM32CubeIDE**
- **SEGGER J-Link** debugger and programmer

Embit also provides ready-to-use firmware that allows the module to act as a simple modem over UART. This AT-like protocol is named "**EBI**" (**Embit Binary Interface**). By exploiting a set of binary commands it is possible to configure the module, send/receive data over the air and develop complex application without the need of writing complex custom firmware.

## 3 Size and footprint

### 3.1 Size

The mechanical dimensions of **EMB-LR1280S** are 15.5 x 20 mm with a thickness of 2.3 mm. The module has a total of 28 pins (10 on each side edge and 8 on bottom side) with 1 mm pitch and 1.02 x 0.81 as dimensions. Positioning is shown in the following image (Figure 2).

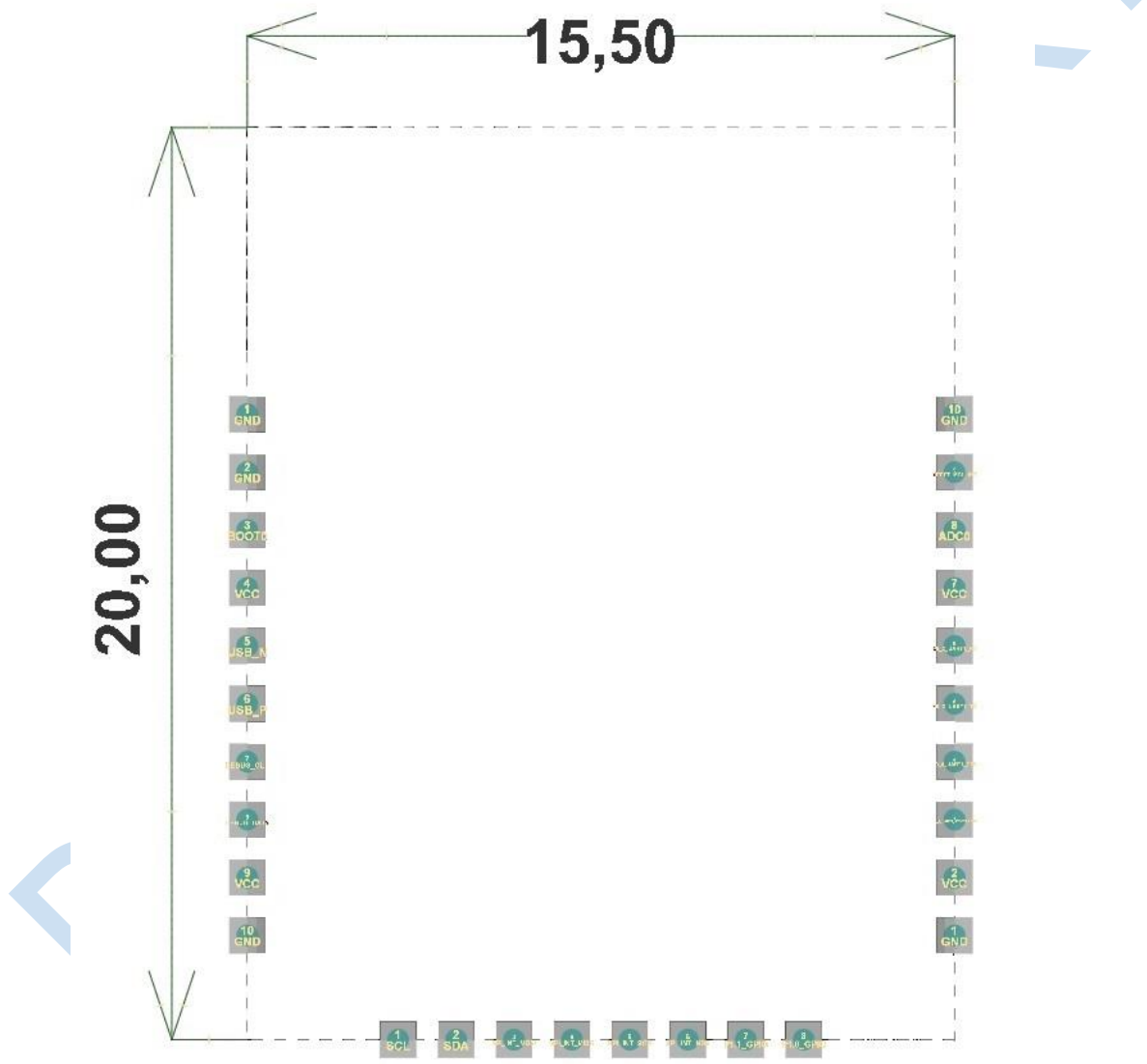

Figure 2: Connector positions



### 3.2 Suggested footprint

The **EMB-LR1280S** suggested footprint consists in 28 LGA pads positioned as following (Figure 3 and Figure 4, all sizes are in mm).

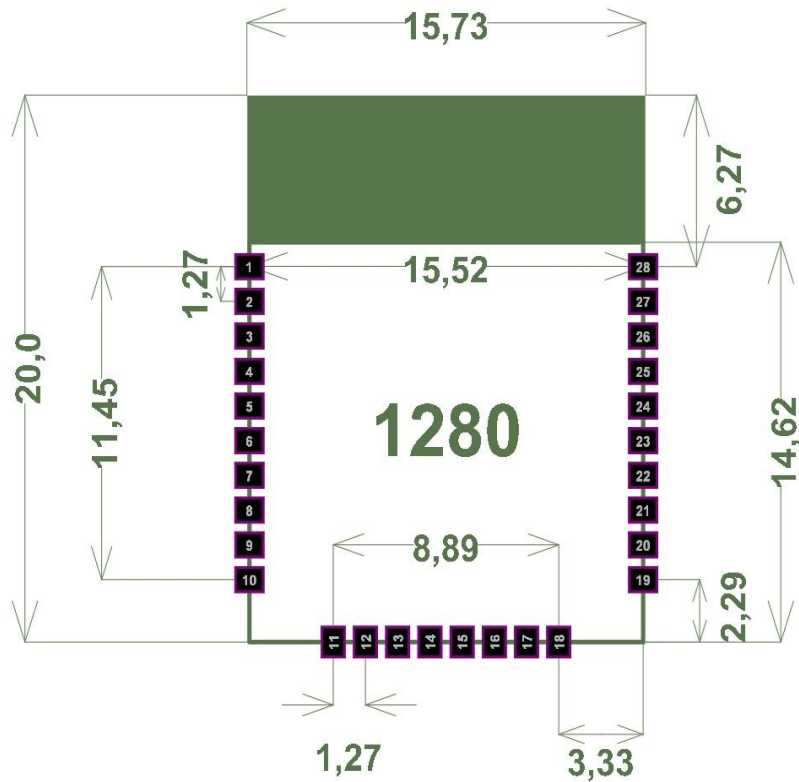

Figure 3: EMB-LR1280S suggested footprint

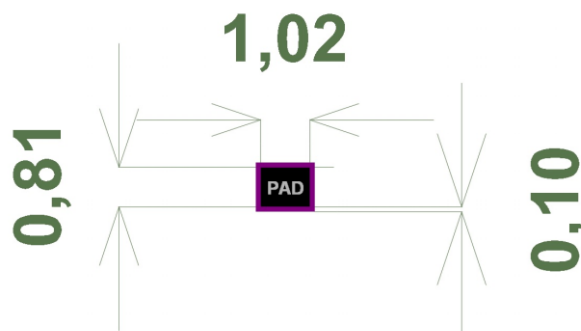

Figure 4: Pad

### 3.3 Notes

- The area underneath the module must be kept free of components (both top and bottom layers) and must be covered with solder resist.
- The PCB top layer underneath the module must be free of nets, power planes and vias. The bottom layer shall provide a ground plane.
- The power supply of the module must be as clean as possible; it must be decoupled placing a ceramic capacitor as near as possible at the Vcc pins, additional filtering made by a ferrite bead is recommended.
- Noisy electronic components (such as switching power supply) must be placed as far as possible and adequately decoupled.
- The ground pins of the module shall be connected to a solid ground plane.

**Note:** Taking no account this recommendation may affect the radio performances.

PRELIMINARY

## 4 Connections

### 4.1 Module pinout

Number	Pin Name	Type	Description
1	BOOT0	Boot0 input	BOOT0 pin
2	GND1	GND	Ground
3	GND2	GND	Ground
4	VCC	Power Input	Supply voltage
5	PA11_USB_N	Digital I/O	USB N
6	PA12_USB_P	Digital I/O	USB P
7	DEBUG_CLK	JTAG	SWD Debug port clock
8	DEBUG_DATA	JTAG	SWD Debug port data
9	VCC	Power Input	Supply voltage
10	GND3	GND	Ground
11	PB8_I2C_SCL	Digital I/O	I2C1 SCL
12	PB9_I2C_SDA	Digital I/O	I2C1 SDA
13	PB15_SPI_MOSI	Digital I/O	SPI MOSI
14	PB14_SPI_MISO	Digital I/O	SPI MISO
15	PB10_SPI_SCK	Digital I/O	SPI SCK, LPUART RX
16	PB12_SPI_NSS	Digital I/O	SPI NSS
17	PA1_GPIO0	Analog/Digital I/O	ADC_IN1
18	PA2_GPIO1	Analog/Digital I/O	ADC_IN2, LPUART TX
19	GND4	GND	Ground
20	VCC	Power Input	Supply voltage
21	PB3_UART_RTS	Digital I/O	UART RTS
22	PB4_UART_CTS	Digital I/O	UART CTS
23	PA9_UART_TX	Digital I/O	UART TX
24	PA10_UART_RX	Digital I/O	UART RX
25	VCC	Power Input	Supply voltage
26	PA0_ADC	Analog/Digital I/O	ADC_IN0
27	NRESET	Reset input	System reset input (active low)
28	GND5	GND	Ground

**Table 1: EMB-LR1280S Interface Pin Out.**

**Note:** All Digital I/O support the MCU interrupt request.

## 4.2 *Typical application circuit*

The external supply shall include protection from spikes, short circuits and it requires adequate decoupling.

- Voltage glitches on VCC supply may cause reset or malfunctioning of the microcontroller.
- Slow voltage ramp on VCC or NRESET may cause malfunctioning of the microcontroller.
- Do not reset or turn off the power of the module while writing to the flash; otherwise memory corruption may occur.

PRELIMINARY

## 5 Electrical characteristic

### 6.1 Absolute Maximum Ratings

Parameter	Value	Unit
Power Supply Voltage	+3.9	V
Voltage on any pin	+3.9	V
Rf input power ( $P_{max}$ )	+10	dBm
Storage Temp. Range	-40 ~ +85	°C

Table 2: Absolute maximum ratings.

### 6.2 Operating Conditions

Parameter	Min	Max	Unit
Power Supply Voltage (Vcc)	+1.8	+3.6	V
Operating Temperature range	-40	+85	°C
Logic Input Low Voltage	Vss	0.3*Vcc	V
Logic Input High Voltage	0.7*Vcc	Vcc	V
Logic Output Low Level	Vss	Vss + 0.45	V
Logic Output High Level	Vcc-0.45	Vcc	V

Table 3: Operating Conditions.

### 6.3 Power Consumption

Mode	Typ. value	Unit
Transmit @+12.5 dBm	34	mA
Receive	9.5	mA
Sleep	2.5	μA
XLP Sleep	≤1	μA

Table 4: Power Consumption.

## 6.4 RF Characteristics

Condition	Min.	Typ.	Max.	Unit
RF Frequency range	2400		2485	MHz
Frequency tolerance		±10		ppm
Programmable Output Power Range	-18		+12.5	dBm
RF Data Rate LoRa®	0.595		253.9	kbps
Receiver sensitivity SF5; BW=203 KHz		-109		dBm
Receiver sensitivity SF6; BW=203 KHz		-111		dBm
Receiver sensitivity SF7; BW=203 KHz		-115		dBm
Receiver sensitivity SF8; BW=203 KHz		-118		dBm
Receiver sensitivity SF9; BW=203 KHz		-121		dBm
Receiver sensitivity SF10; BW=203 KHz		-124		dBm
Receiver sensitivity SF11; BW=203 KHz		-127		dBm
Receiver sensitivity SF12; BW=203 KHz		-130		dBm

Table 5: RF characteristics.

## 6 References

- [1] STM, STM32L073CZ Datasheet from [www.st.com](http://www.st.com)
- [2] Semtech, SX1280 Datasheet from [www.semtech.com](http://www.semtech.com)

PRELIMINARY

## 7 Disclaimer of liability

The user must read carefully all the documentation available before using the product. In particular, care must be taken in order to comply with the regulations (e.g., power limits, duty cycle limits, etc.).

### 7.1 Handling Precautions



This product is an ESD sensitive device. Handling precautions should be carefully observed.

### 7.2 Limitations

Every operation involving a modification on the internal components of the module will void the warranty.

### 7.3 Disclaimer of Liability

The information provided in this and other documents associated to the product might contain technical inaccuracies as well as typing errors. Regulations might also vary in time. Updates to these documents are performed periodically and the information provided in these manuals might change without notice. The user is required to ensure that the documentation is updated and the information contained is valid. Embit reserves the right to change any of the technical/functional specifications as well as to discontinue manufacture or support of any of its products without any written announcement.

### 7.4 Trademarks

Embit is a registered trademark owned by Embit s.r.l.

All other trademarks, registered trademarks and product names are the sole proprietary of their respective owners.